

LNTM-25 PRO Wire Feeder



Portable Industrial Wire Feeders

Built upon the tradition and success of the LNTM-25, the new LNTM-25 PRO is designed to be simple, reliable and easy to service. The LNTM-25 PRO is ideal for field construction and fabrication, shipyards, and rental companies.

The MAXTRAC[®] wire drive enhances performance, while the replacement case, and many other upgrade options that can be installed in less than five minutes aid in the serviceability.

The LNTM-25 PRO is available in standard and extra torque models. All models include a gas solenoid and flow meter to run both flux-cored and MIG wires.

The extra torque model features additional torque gearing for reliable feeding of large diameter flux-cored wires.



Output



Input



Processes

MIG, Pulsed, Cored

Advantage Lincoln

Performance

- 2-Step/trigger interlock provides comfort for long welds.
- Analog Voltmeter with polarity indicator LED automatically adjusts to welding polarity.
- Non-linear wire feed speed gives single range control, yet maintains sensitivity with low wire feed speed.
- Sturdier and rugged spindle design with an incorporated brake.

Reliability

- Lightweight, impact and flame resistant polycarbonate case design keeps the internal components protected.
- Potted and trayed PC board protects against moisture and corrosion.
- Reel locking mechanism eliminates spindle cross threading.

Serviceability

- Case can be replaced in less than 5 minutes – eliminates downtime.
- Timer kit available to prevent the electrode from sticking in the crater when using high wire feed speeds.

TECHNICAL SPECIFICATIONS

Product Name	Product Number	Input Power	Output Capacity Current / Duty Cycle	Gas solenoid & flow meter	Wire Feed Speed Range ipm (m/min)	Wire Size Range in. (mm)			Dimensions H x W x D in (mm)	Net Weight lbs (kg)
						Solid	Cored	Aluminum		
LN TM -25 PRO Standard	K2613-1	15-110 VDC	325A/100% 450A/60%	Yes	50-700 (1.3-17.7)	.023-1/16" (0.6-1.6)	.030-5/64" (0.8-2.0)	.035-1/16" (0.9-1.6)	15x8x22 (381 x 203 x 558)	37 (16)
LN TM -25 PRO Extra Torque	K2613-2				30-400 (0.8-10.1)		.030-3/32" (0.8-2.4)			

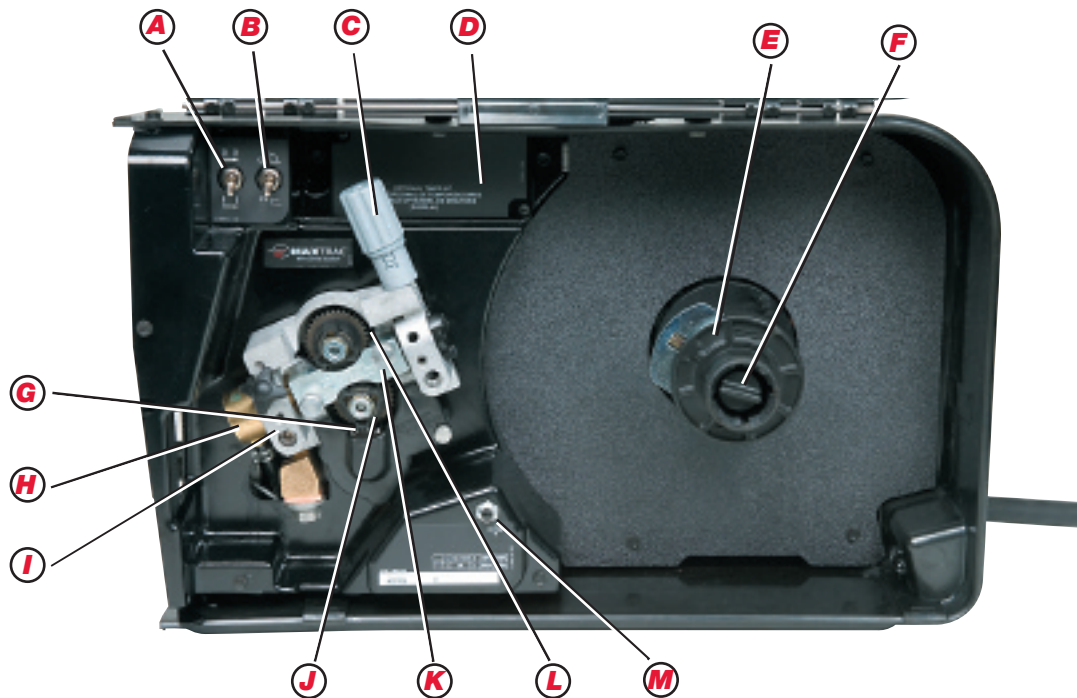

A 2 Step/Trigger Interlock Switch
 • Provides comfort for long welds.

B CV/CC Switch
 • Allows use of CC power source.

C Patented Dual Spring Pressure Arm
 • Easy turn numeric tension indicator
 • Set heavy tension for steel and stainless
 • Set moderate tension for cored wires
 • Set soft tension for aluminum
 • Wide idler arm hinge delivers improved drive roll clamping pressure

D Optional Timer Kit (Preweld, Postflow & Burnback)
 • Prevents electrode from sticking in crater when using high wire feed speeds

E Spool Retainer
F Spindle Brake
 • Heavy-duty design with an adjustable brake incorporated

G Separate Drive Gear
 • Reduces pressure on motor for extended service life

H Brass to Brass Interchangeable Gun Bushings
 • More reliable electrical conductivity – no oxide build-up
 • More efficient energy transfer – lower voltage drops
 • Easily adapt any number of Lincoln Magnum® or competitive guns

I Rigid Cast Aluminum Frame
 • Enhances precise drive roll alignment

J Patent-Pending Drive Rolls (not shown)
 • For steel - new design delivers 20% more feeding force
 • For aluminum - chrome-plated to resist build-up

K Patented Split Wire Guides
 • Full support for wire throughout the drive path
 • Removable outer wire guide for easy access
 • No tools required
 • No birdnesting

L Twist-Lock Drive Roll Hubs
 • Fast, tool-less changeovers

M Cold Feed Switch
 • Provides added safety by keeping welding wire electrically “cold” until trigger is pressed.

FEATURES



1. Analog Voltmeter
2. Wire Feed Speed Knob
3. 5 Pin Gun Trigger Connector
4. Work Sense Lead
5. Thermal Protection LED
6. Welding Polarity Indicator LED

Standard and Extra-Torque Model

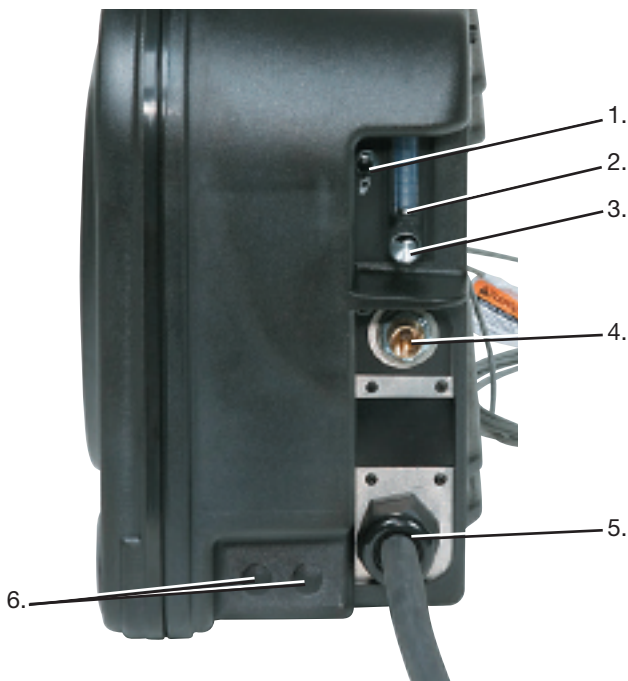

1. Gas Purge Pushbutton
2. Flow Meter Ball
3. Flow Meter Valve
4. Shielding Gas Inlet
5. Electrode Lead
6. Optional Water Cooled Gun Connections

A CLOSER LOOK

EASY CASE REPLACEMENT IN MINUTES - Now a damaged case does not require ordering a new unit!

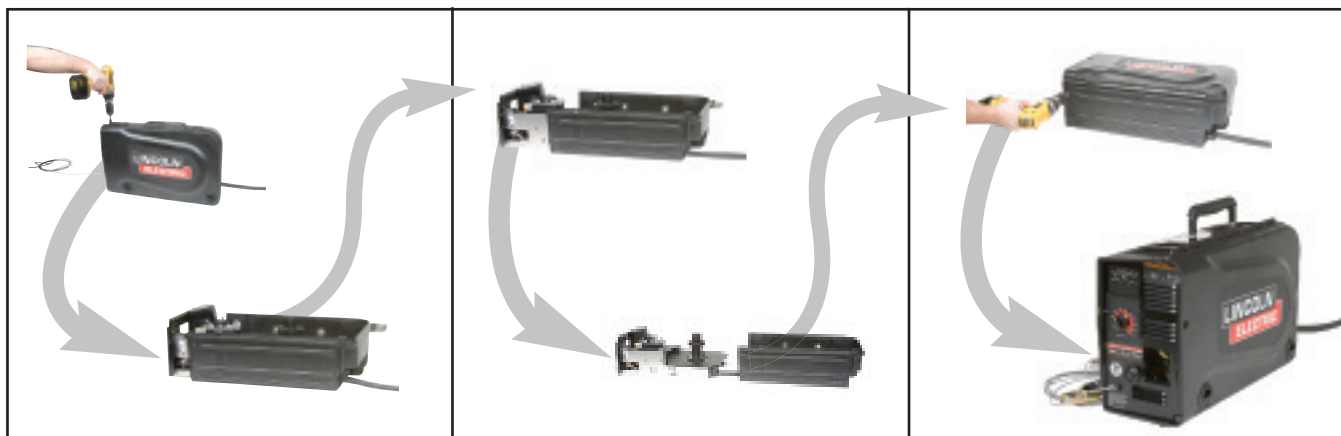

① Remove Screws

② Remove inside frame from case

③ Put frame in a new case and replace screws

RELIABILITY

Spindle



- Sturdier, rugged design with an incorporated brake.
- Quick-release reel locking mechanism eliminates cross threading.

Contactors



- High duty cycle rating 450A/60%

PC Board



- Potted and trayed for protection against moisture, dust, and corrosion.

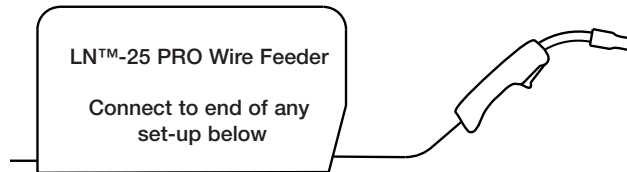

**ACROSS THE ARC SET-UP
(with Electrode Cold Operation)**

*(Connections are for current equipment design.
Subject to change without notice.)*

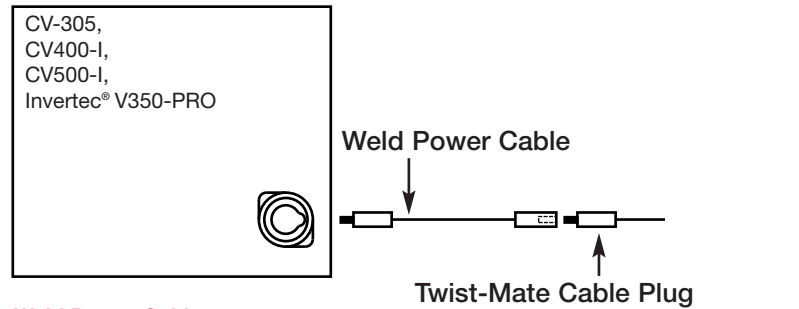
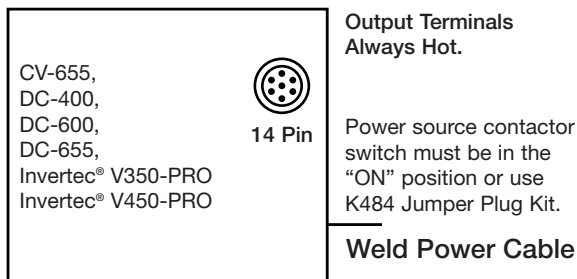
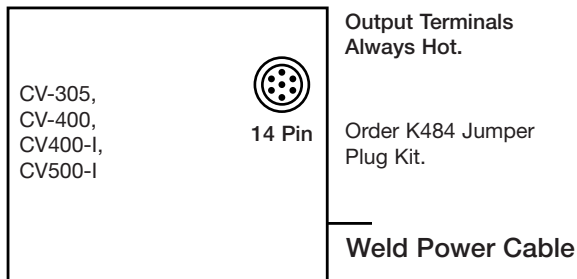
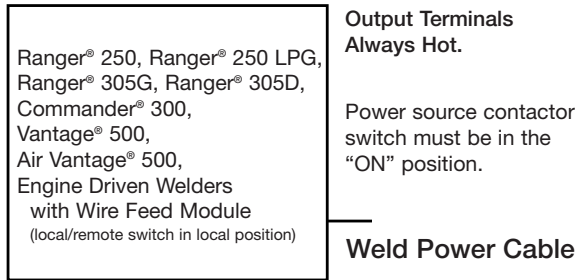
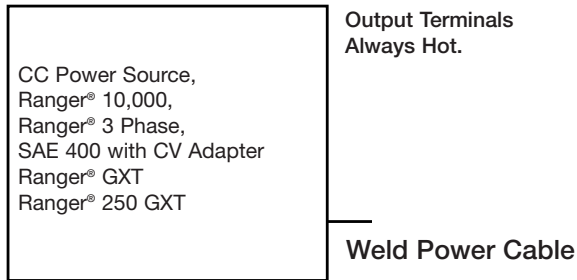

- Weld Power Cables**
K1841-25 Twist-Mate to Twist-Mate, 1/0, 350A, 60% duty cycle, 25 ft. (7.6m)
K1841-50 Twist-Mate to Twist-Mate, 2/0, 350A, 60% duty cycle, 50 ft. (15.2m)

- Twist-Mate Cable Plugs**
K852-95 for 2/0-3/0 cable

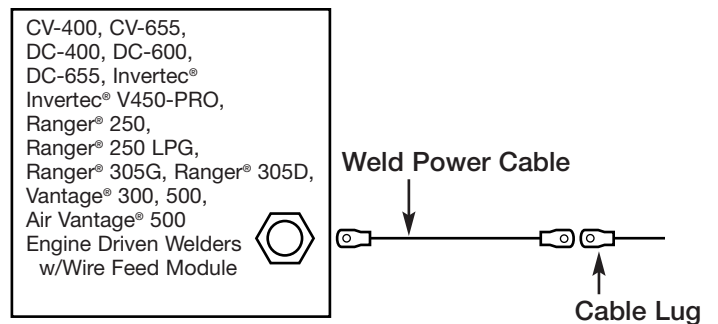

- Weld Power Cables**
K1842-10 Lug to Lug, 3/0, 600A, 60% duty cycle, 10 ft. (3.0m)
K1842-35 Lug to Lug, 3/0, 600A, 60% duty cycle, 35 ft. (10.6m)
K1842-60 Lug to Lug, 3/0, 600A, 60% duty cycle, 60 ft. (18.2m)
K1842-110 Lug to Lug, 4/0, 600A, 60% duty cycle, 110 ft. (33.5m)

For best performance, use Lincoln Electric® power sources and consumables.

OPTIONS

UNIT INCLUDES

Standard Model

- Gas solenoid
- Flow meter
- Gun bushings (K1500-2 installed, K1500-1 shipped loose)

Extra Torque Model

- Additional gearing for reliable feeding of large diameter cored wires.
- Gas solenoid
- Flow meter
- Gun bushings (K1500-2 installed, K1500-1 shipped loose)

DRIVE ROLL & WIRE GUIDES REQUIRED



DRIVE ROLL & WIRE GUIDE KITS

Description	Order No.
Steel Wire Sizes (includes stainless steel):	
.023-.030" (0.6-0.8 mm)	KP1696-030S
.035" (0.9 mm)	KP1696-035S
.045" (1.2 mm)	KP1696-045S
.052" (1.4 mm)	KP1696-052S
.035", .045" (0.9, 1.2 mm)	KP1696-1
.040" (1.0 mm)	KP1696-2
1/16" (1.6 mm)	KP1696-1/16S
Cored Wire Sizes:	
.030-.035" (0.8-0.9 mm)	KP1697-035C
.040-.045" (1.0-1.2 mm)	KP1697-045C
.052" (1.4 mm)	KP1697-052C
1/16" (1.6 mm)	KP1697-1/16C
Steel or Cored Wire Sizes:	
.068-.072" (1.8 mm)	KP1697-068
5/64" (2.0 mm)	KP1697-5/64
3/32" (2.4 mm)	KP1697-3/32
Aluminum Wire Sizes:	
.035" (0.9 mm)	KP1695-035A
.040" (1.0 mm)	KP1695-040A
3/64" (1.2 mm)	KP1695-3/64A
1/16" (1.6 mm)	KP1695-1/16A

WELD POWER CABLE REQUIRED

WELD POWER CABLES	
Description	Order No.
Twist-Mate™ to Lug, 1/0, 350A, 60% duty cycle, 10 ft. (3.0 m)	K1840-10
Lug to Lug, 3/0, 600A, 60% duty cycle, 10 ft. (3.0 m)	K1842-10
Lug to Lug, 3/0, 600A, 60% duty cycle, 35 ft. (10.6 m)	K1842-35
Lug to Lug, 3/0, 600A, 60% duty cycle, 60 ft. (18.2 m)	K1842-60
Lug to Lug, 4/0, 600A, 60% duty cycle, 110 ft. (33.5 m)	K1842-110
Twist-Mate™ to Twist-Mate™, 1/0, 350A, 60% duty cycle, 25 ft. (7.6 m)	K1841-25
Twist-Mate™ to Twist-Mate™, 2/0, 350A, 60% duty cycle, 50 ft. (15.2 m)	K1841-50

FEED PLATE GUN RECEIVER BUSHINGS

K1500-1 Gun Receiver Bushing *	K1500-2 Gun Receiver Bushing (Standard)	K1500-3 Gun Receiver Bushing (Optional)	K1500-4 Gun Receiver Bushing (Optional)	K1500-5 Gun Receiver Bushing (Optional)	K489-7 Fast-Mate Gun Receiver Bushing (Optional)
<ul style="list-style-type: none"> • Magnum® 200, 300 and 400 gun and cable assemblies with K466-1 connector kit. • Lincoln Innershield® gun and cable assembly. • Magnum® 550 gun and cable assembly with K613-1 connector kit. 	<ul style="list-style-type: none"> • Magnum® 200 and 400 fully assembled guns (K497-2x and K471-2x). • Magnum® 200, 300 and 400 gun and cable assemblies with K466-10 connector kit. • Guns with Tweco® #2, #3, and #4 connectors. 	<ul style="list-style-type: none"> • Magnum® 550 gun and cable assembly with K613-7 connection. • Guns with Tweco® #5 connectors. 	<ul style="list-style-type: none"> • Magnum® 200, 300 and 400 gun and cable assemblies with K466-3 connector kit. 	<ul style="list-style-type: none"> • To adapt to OXO® guns. 	<ul style="list-style-type: none"> • Magnum® gun and cable assemblies with Fast-Mate connections. • Handles both single and dual procedure guns.

* Shipped loose with every unit.



GENERAL OPTIONS



Magnum® Gas-Shielded Gun and Cable Assemblies
Available 200-550 amps, air-cooled, gas-shielded welding guns.
See publication E12.10



Magnum® Self-Shielded Gun and Cable Assemblies
Available 250-600 amps.
See publication E12.110

Preflow, Postflow and Burnback Timer Kit

Provides adjustable delay of power source output shut off to prevent electrode sticking in crater when using high wire feed speeds.
Order K2330-2



Jumper Plug Kit
For use with CV only power sources with 14 pin MS-type wire feeder connections and no contactor control switch. Jumper plug kit closes contactor for always hot welding output.
Order K484



14 lb. Innershield® Coil Adapter
Permits 14 lb. (6 kg) Innershield® electrode coils to be mounted on 2" (51mm) O.D. spindles. Wire not included.
Order K435



8" O.D. Spool Adapter
For small spools. Permits 8" (203mm) O.D. spools to be mounted on 2" (51mm) O.D. spindles.
Order K468



Replacement Case Kit
Replace a damaged case without replacing the entire unit.
Order K2596-1 (aluminum)
Order K2596-2 (plastic)



Twist-Mate Cable Plug
For connecting welding cable to output terminal receptacles. For 2/0 – 3/0 (70 – 95 mm²) cable.
Order K852-95



Micro Wire Straightener
Straightens .035"–1/16" (0.9–1.6mm) wire for use with portable feeders.
Order K1733-4 for Power Feed™ 25M

LN™-25 PRO WIRE FEEDER ORDER FORM

PRODUCT DESCRIPTION	ORDER NUMBER	QUANTITY	PRICE
LN™-25 PRO Wire Feeder Standard	K2613-1		
LN™-25 PRO Wire Feeder Extra Torque	K2613-2		
Unit Requires			
Weld Power Cable	See page 5 and 6		
Magnum® Gas-Shielded Gun and Cable Assemblies	See publication E12.10		
Magnum® Self-Shielded Gun and Cable Assemblies	See publication E12.110		
Required Options			
Drive Roll and Guide Tube Kits	See page 6		
Recommended General Options			
Preflow, Postflow and Burnback Time Kit	K2330-2		
Jumper Plug Kit	K484		
22-30 lb. Readi-Reel Adapter	K363P		
14 lb. Innershield Coil Adapter	K435		
8" O.D. Spool Adapter	K468		
Aluminum Case Replacement Kit	K2596-1		
Plastic Case Replacement Kit	K2596-2		
Micro Wire Straightener	K1733-4		
	TOTAL:		

CUSTOMER ASSISTANCE POLICY

The business of The Lincoln Electric Company is manufacturing and selling high quality welding equipment, consumables, and cutting equipment. Our challenge is to meet the needs of our customers and to exceed their expectations. On occasion, purchasers may ask Lincoln Electric for advice or information about their use of our products. We respond to our customers based on the best information in our possession at that time. Lincoln Electric is not in a position to warrant or guarantee such advice, and assumes no liability, with respect to such information or advice. We expressly disclaim any warranty of any kind, including any warranty of fitness for any customer's particular purpose, with respect to such information or advice. As a matter of practical consideration, we also cannot assume any responsibility for updating or correcting any such information or advice once it has been given, nor does the provision of information or advice create, expand or alter any warranty with respect to the sale of our products.

Lincoln Electric is a responsible manufacturer, but the selection and use of specific products sold by Lincoln Electric is solely within the control of, and remains the sole responsibility of the customer. Many variables beyond the control of Lincoln Electric affect the results obtained in applying these types of fabrication methods and service requirements.

Subject to Change – This information is accurate to the best of our knowledge at the time of printing. Please refer to www.lincolnelectric.com for any updated information.



THE LINCOLN ELECTRIC COMPANY

22801 St. Clair Ave., Cleveland, OH 44117-1199 • 216.481.8100 • www.lincolnelectric.com